

Musicians have always been interested in the evolution of their instruments. This evolution might be done either to adapt an instrument's quality to musicians' and composers' needs, or to enable it to produce new sounds. In this study, we want to control the sound quality and playability of wind instruments, using modal active control. The modal active control makes it possible to modify the input impedance (frequency, gain and damping) of these instruments and to modify the instrument's quality. The simulations for a first experiment are presented here.

We simulate a control of the modes (frequency, damping) of a cylinder, which is considered as a simple "wind instrument". We consider the use of a microphone, a speaker, an observer and a controller to modify these modes, then we look at the modifications on the sound and playability using *Modalys*. Our next goal will be to apply the control to a real cylinder, and to evaluate it in a musical context with a musician.

## 1 Introduction

Musicians have always been interested in the evolution of their instruments. This evolution might be done either to adapt an instrument's quality to musicians' and composers' needs, or to enable it to produce new sounds.

Using active control, instruments can produce new sounds, while keeping the musician gesture and the instrument as a radiator [1].

There are two main active control methods : feedforward [2, 3, 4, 5] and feedback [3, 5, 6, 7, 8, 9, 10]. Applied to a duct, the feedforward method consists of getting a signal with a microphone before a speaker to modify it after the speaker. The feedback method implies that the control has an influence on the signal getting place.

The feedback modal active control method is chosen and applied to a cylindrical tube, which is considered as a simple "wind instrument", in order to modify its eigenmodes. The aim is to change the damping and the frequency of the different modes of the tube. This is done using colocated microphone and speaker, linked by a DSP containing an observer and a controller (see Figure 1).

The modal active control, including the state-space model of the tube, is presented. Then two examples of the simulations using this model are shown and discussed.

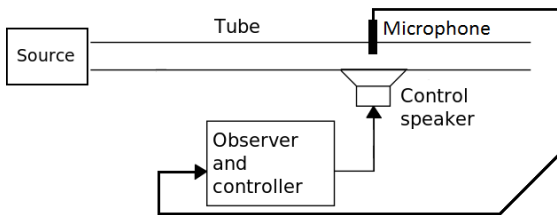

Figure 1: Tube with control system

## 2 Modal Active Control

The modal active control allows the control of the damping and the frequency of the eigenmodes of a system. To apply this control, it is necessary to build a model of the system. A state-space model of the system is implemented.

### 2.1 State-Space Model

The State-space model of acoustic ducts developed in [8] is used and adapted to the simulation and experimental needs, using [11, 12, 13, 14]. The diameter  $R$  of the duct is sufficiently small compared to its length  $L$  ( $R \ll L$ ) so that the duct is a one-dimensional waveguide with spatial coordinate  $x$ , where  $0 \leq x \leq L$ . The control speaker is placed at  $x = x_s$ .

The microphone is placed at the same location ( $x_m = x_s$ ). The pressure in the duct is described by:

$$\frac{1}{c^2} \frac{\partial^2 p(x, t)}{\partial t^2} = \frac{\partial^2 p(x, t)}{\partial x^2} + \rho_0 \frac{dv_s(t)}{dt} \delta(x - x_s) \quad (1)$$

where  $p$  is the acoustic pressure,  $\rho_0$  is the density of the acoustic medium,  $c$  the velocity of sound in the medium and  $v_s$  the speaker baffle velocity.

Using separation of variables, let

$$p(x, t) = q(t)V(x) \quad (2)$$

Using equations (1) and (2) gives

$$\ddot{q}_i(t) + \lambda_i q_i(t) = b_i u_s(t) \quad (3)$$

where  $u_s(t) = \rho_0 dv_s(t)/dt$ ,  $\lambda$  is a positive constant and  $b_i = V_i(x_s)$ .  $V(x)$  is such that

$$V_{xx}(x) + \frac{\lambda}{c^2} V(x) = 0 \quad (4)$$

Hence,

$$V(x) = \alpha \sin(kx) + \beta \cos(kx) \quad (5)$$

with  $k^2 = \lambda/c^2$ . From the closed-open boundary conditions, there is

$$V(L) = 0 \quad (6)$$

$$V'(0) = 0 \quad (7)$$

This implies  $\alpha = 0$  and  $\cos(kL) = 0$ , then  $k_i = (2i + 1)\pi/2L$ . Therefore

$$V_i(x) = \beta \cos(k_i x) \quad (8)$$

$V_i(\cdot)$  is scaled so that

$$\left( V_i(\cdot), \frac{1}{c^2} V_j(\cdot) \right) = \frac{1}{c^2} \int_0^L V_i(x) V_j(x) dx = \delta_{ij} \quad (9)$$

where  $\delta_{ij}$  is the Kronecker delta. This implies that

$$\beta = c \sqrt{\frac{2}{L}} \quad (10)$$

and thus

$$V_i(x) = c \sqrt{\frac{2}{L}} \cos(k_i x) \quad (11)$$

To obtain a state-space description of the acoustic duct, without considering the modes of the speaker, let

$$x(t) = \begin{bmatrix} q_i \\ \dot{q}_i \end{bmatrix} \quad (12)$$

so that

$$\dot{x}(t) = Ax(t) + Bu_s(t) \quad (13)$$

$$y(t) = Cx(t) \quad (14)$$

where

$$A = \begin{bmatrix} 0_{r,r} & I_{r,r} \\ -diag(\omega_i^2) & -diag(2\xi_i\omega_i) \end{bmatrix} \quad (15)$$

is the *system matrix* [15],  $I$  is the identity matrix,

$$B = \begin{bmatrix} 0_{r,1} \\ b_i \end{bmatrix} \quad (16)$$

is the *actuator matrix* (the speaker matrix) and

$$C = \begin{bmatrix} V_i(x_m) & 0_{1,r} \end{bmatrix} \quad (17)$$

is the *sensor matrix* (the microphone matrix).

A disturbance signal  $w(t)$  located at  $x = 0$  is introduced. Then

$$\dot{x}(t) = Ax(t) + Bu_s(t) + D_1w(t) \quad (18)$$

where

$$D_1 = \begin{bmatrix} 0_{1,r} \\ V_i(x_d) \end{bmatrix} \quad (19)$$

is the *disturbance matrix*.

## 2.2 Control of the eigenmodes

The control is done using pole placement. The coordinates of the poles are defined by the damping and the angular frequency of each mode [11 ,12] (see Figure 2):

$$Re(pole_n) = \xi_n\omega_n \quad (20)$$

and

$$Im(pole_n) = \pm\omega_n\sqrt{1-\xi_n^2} \quad (21)$$

where  $\xi_n$  and  $\omega_n$  are the damping and the angular frequency of the  $n$ th mode.

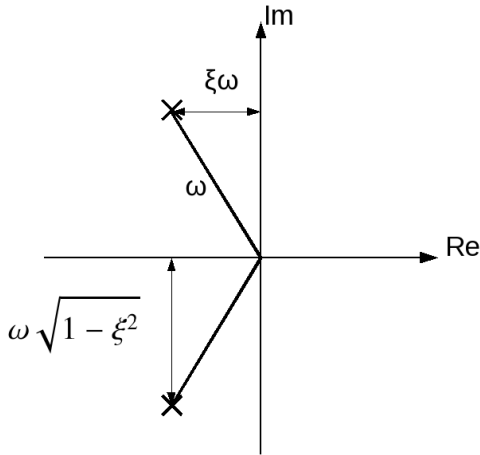

Figure 2: Single degree of freedom oscillator [12]

It is then possible to choose the damping and the frequency of each mode. Practically, the observer generates a control gain vector  $K$  and an observation gain vector  $L$  (see Figure 3). The control gain vector  $K$  is chosen such that

$$\det[sI - (A - BK)] = 0 \quad (22)$$

where  $s = i\omega$ . The observation gain vector  $L$  is used in the observer control loop such that

$$L(y - \hat{y}) \rightarrow 0 \quad (23)$$

The simulations show transfer functions obtained in open loop (without control) and closed loop (with control). Open loop transfer function  $H_{OL}$  is [13]:

$$H_{OL} = C(sI - A)^{-1}D_1 \quad (24)$$

Closed loop transfer function  $H_{CL}$  is :

$$H_{CL} = C(sI - (A - BK(sI - (A - BK - LC))^{-1}LC))^{-1}D_1 \quad (25)$$

## 3 Simulations of the control of the eigenmodes

The frequency domain simulations are done using *Matlab*, and the time domain simulations with a clarinet-like reed excitation are done using *Modalys*.

### 3.1 Simulation of control

The simulation is made with a tube with length  $L = 1.2m$  and radius  $R = 0.0155m$ . The speaker and the microphone are placed at the entrance of the tube ( $x_s = x_m = 0$ ). The natural frequencies and damping of the tube are determined with an input impedance algorithm [17]. As the system is a closed-open tube, the impedance peaks have frequencies such that  $f_{n+1} = (2n + 1)f_0$ . With this tube, the fundamental frequency is 71Hz. Only the 10 first modes are modeled. The pole placement is obtained using Matlab *place* function.

#### 3.1.1 Control of the damping of Mode 1

Figure 4 a) and b) show respectively the transfer function at the entrance of the tube and the pole diagram in open loop and closed loop. Here, the real part of the first pole is changed, from -3.136 to -9.409 ( $\times 3$ ) and its imaginary part remains the same,  $\pm 445$ . This has been done in order to obtain a damping 3 times higher. This implies a 7dB decrease of the amplitude.

#### 3.1.2 Control of the frequency of Mode 1

Figures 5 a) and b) show the transfer function at the entrance of the tube and the pole diagram in open loop and closed loop. Here, the real part of the first pole is changed, from -3.136 to -2.215 ( $\times 0.71$ ) and its imaginary part is changed, from  $\pm 445$  to  $\pm 314$  ( $\times 0.71$ ). This has been done in order to obtain a change in the frequency, from 71Hz to 50Hz. It implies also a 40dB increase of the amplitude (see part 4).

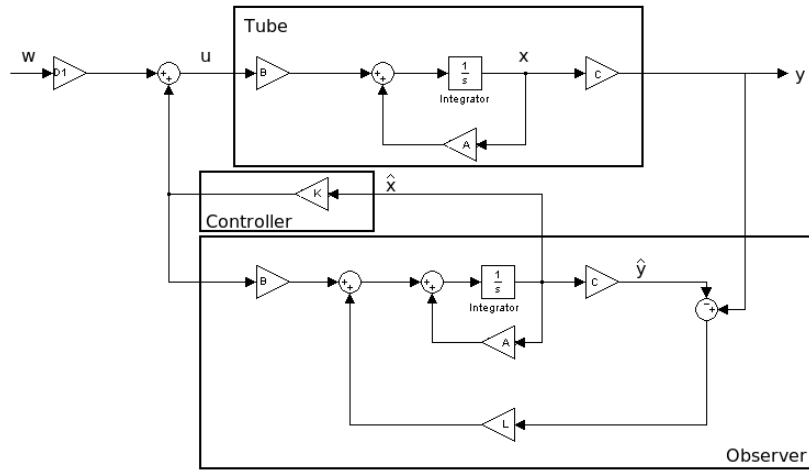

Figure 3: State-space control schematic [14]

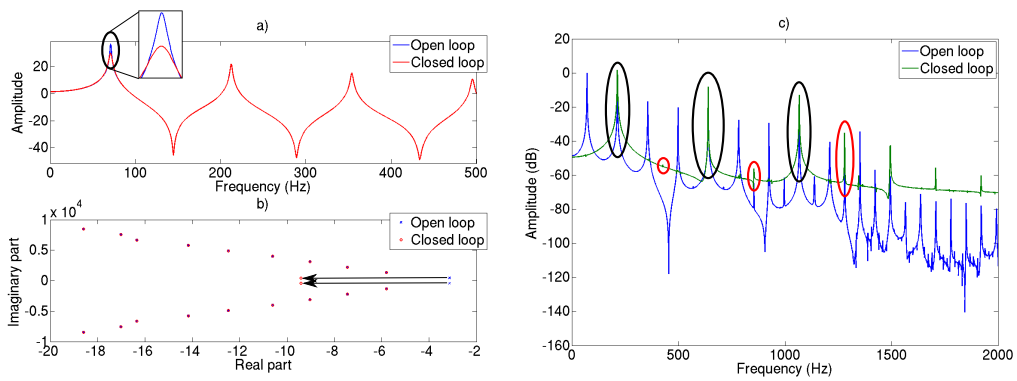

Figure 4: Control of the damping of mode 1 - a) Transfer function at entrance, b) Poles, c) Spectrum of sound

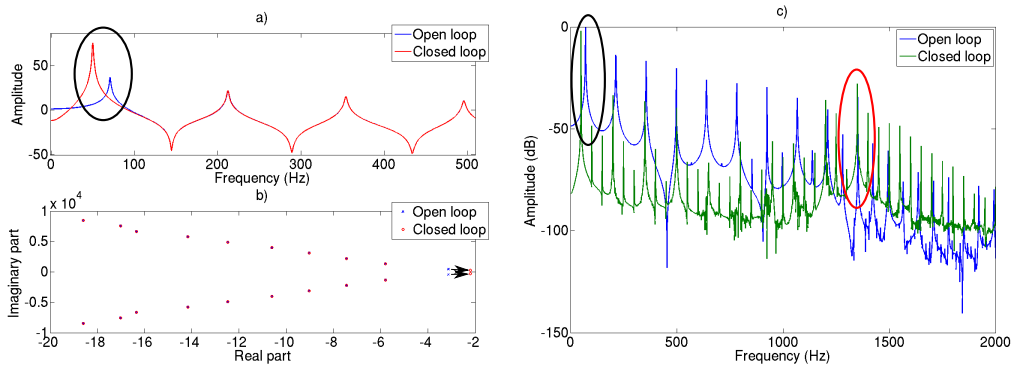

Figure 5: Control of the frequency of mode 1 - a) Transfer function at entrance, b) Poles, c) Spectrum of sound

## 3.2 Sound synthesis with clarinet-like reed excitation

Sound synthesis with clarinet-like reed excitation is done using *Modalys*, by implementing the modes properties of a cylindrical tube in open loop and closed loop.

### 3.2.1 Control of the damping of mode 1

**Steady state** Figure 4 c) shows the spectrum of the sound produced by *Modalys* for the open loop and closed loop cases, when the damping of mode 1 is controlled (the damping is 3 times higher when controlled). The first consequence on the harmonic sound spectrum is a jump to the second mode (the twelfth is played). Playing on the second mode implies the sound to have the odd harmonics of this mode (circled black, modes 2, 5 and 8), with an increase of the amplitude of these resonances (+15dB at 213Hz, +18dB at 640Hz, +22dB at 1067Hz). The amplitude of the even multiples is increased too (circled red), particularly at 1280Hz (+17dB). The effect of the increase of the damping of mode 1 is the same when opening a register key on wind instruments. Recently, the same effect has been observed when the altitude of the pad of the C-hole of the oboe is differently adjusted [18].

**Transient** Figure 6 shows the attack transient when blowing through a clarinet-like reed in the tube. The three graphs are done blowing exactly in the same way in the tube. It shows that the transient is longer in the closed loop case. There are some jumps between modes 1 and 2, but after five seconds, the playing stabilizes on the second mode.

### 3.2.2 Control of the frequency of Mode 1

**Steady state** Figure 5 c) shows the spectrum of the sound produced by *Modalys* when the frequency of mode 1 is controlled (the frequency is changed from 71Hz to 50Hz). As the first mode is no longer in tune with the other modes of the tube, there is a 30dB decrease of the amplitude between 50Hz and 1200Hz. The first peak at 50Hz (circled black) has a high amplitude because of the 40dB increase seen on a). After 1200Hz, and particularly at 1350Hz (circled red), the amplitude is the same than in open loop, and even higher (+7dB at 1350Hz). The 1350Hz increase is due to the fact that the frequency is common between the natural modes of the tube and the harmonics of the sound. The proximity with the reed resonance (1392Hz) is another reason of this increase.

**Transient** Figures 6 a) and c) allow a comparison between the uncontrolled tube and the tube with the control on the frequency of the first mode. The transient is affected a little. Perceptively, One can hear two pitches : a very low frequency one (50Hz) and a high frequency one (1350Hz).

## 4 Discussion

The modal active control using a single microphone and a single speaker localised at the entrance of the tube allows changes in frequency and damping of modes. But other modes can be affected (more than 1dB). The limits before this effect are:

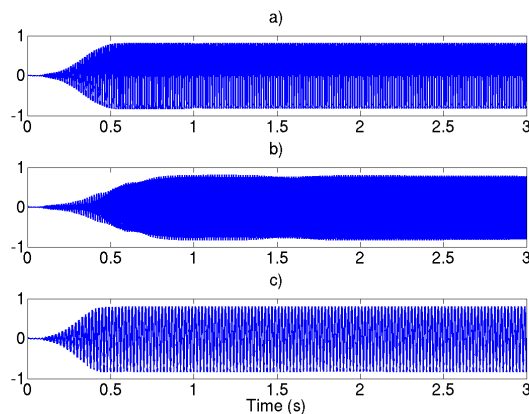

Figure 6: Attack transients on time simulations (*Modalys*). a) Without control, b) Damping of Mode 1 controlled, c) Frequency of Mode 1 controlled

- Damping
  - Decrease : no limits has been found.
  - Increase : the damping can be increased 30 times for the first mode (-25dB). The other modes cannot be changed that much, from 3.5 times (mode 2, -8dB) to 1.7 times (mode 10, -3dB).
- Frequency
  - First mode : the frequency of the first mode can be changed from 10 to 90Hz (natural : 71Hz).
  - Other modes : the frequency of all the other modes (2 to 10) can not be changed more than  $\pm 4$ Hz. Beyond this limit, there is an influence on the amplitude of the other modes. The more the order of the mode is high, the more the influence is high. For example, an increase of 20Hz of the 7th mode implies an increase of the amplitude of the first mode of 21dB, and an increase of 7dB to 2dB of the amplitude of modes 2 to 6.
  - All the modes : each change of the frequency (increase or decrease) comes with an increase of the amplitude of the controlled mode. The amplitude of the first mode is increased by 16dB when the frequency is changed to 90Hz. This increase lowers with the order of the mode but is always higher when increasing the frequency than when decreasing it. This change in amplitude comes with a change of damping of about 10%.

With the current model, it is possible to control the damping independently of the frequency, but it is not possible to control the frequency independently of the damping. Besides, there is a very little possibility of changing the frequency of a mode before there is a consequence on the amplitude of the other modes.

These consequences are the limits of the use of a single microphone and a single speaker with this approach.

## 5 Conclusion and perspectives

A state-space model of a tube and a modal control method have been proposed in order to change the playability and

the sound of a simplified wind instrument. The control allows changes in damping and frequency, especially on the first mode. Some tests about the optimal position of the sensor (microphone) and actuator (speaker) on a specific mode will be done in the future. Then, a first experiment with a speaker, a microphone and a DSP will apply this control to a real tube with the same dimensions, and playing tests will be done with musicians.

## Acknowledgments

This work has been done during the PhD of Thibaut Meurisse, funded by Agence Nationale de la Recherche (ANR IMAREV project) and Université Pierre et Marie Curie (UPMC, Paris). We thank gratefully Joel Bensoam and Robert Piéchaud for their help with *Modalys*.

## References

- [1] H. Boutin, *Méthodes de contrôle actif d'instruments de musique. Cas de la lame de xylophone et du violon*, Thèse, Université Pierre et Marie Curie, 2011.
- [2] P. Lueg, *Process of Silencing Sound Oscillations*, U.S. Patent 2 043 416, 1936.
- [3] E. Friot, *Une introduction au contrôle actif*, Lecture, Laboratoire de Mécanique et d'Acoustique, 2005.
- [4] J. Guérard, *Modélisation numérique et simulation expérimentale de systèmes acoustiques - Application aux instruments de musique*, Thèse, Université Pierre et Marie Curie, 2002.
- [5] PB. Pickett, *An Investigation of Active Tonal Spectrum Control as Applied to the Modern Trumpet*, Master Thesis, Faculty of the Virginia Polytechnic Institute and State University, 1998.
- [6] AJ. Hull, CJ. Radcliffe, SC. Southward, *Global Active Noise Control of a One-Dimensional Acoustic Duct Using a Feedback Controller*, Journal of Dynamic Systems, Measurement, and Control, Vol.115, 1993, pp. 488-494.
- [7] Z. Yang, S. Podlech, *Theoretical Modeling Issue in Active Noise Control for a One-Dimensional Acoustic Duct System*, Proceedings of the 2008 IEEE, International Conference on Robotics and Biomimetics, Bangkok, Thailand, February 21-26, 2009.
- [8] J. Hong et al, *Modeling, Identification, and Feedback Control of Noise in an Acoustic Duct*, IEEE Transactions on Control Systems Technology, Vol. 4, No. 3, May 1996.
- [9] FC. Chen, G. Weinreich, *Nature of the lip reed*, J. Acoust. Soc. Amer., Vol. 99, No. 2, February 1996.
- [10] E. Berdahl, JO. Smith III, G. Niemeyer, *Feedback Control of Acoustic Musical Instruments : Collocated Control Using Physical Analogs*, J. Acoust. Soc. Amer., Vol. 131, Issue 1, pp. 963-973, 2012.
- [11] K. Ogata, *Modern Control Engineering*, Fourth Edition, Prentice Hall, 2002.
- [12] A. Preumont, *Vibration Control of Active Structures, An Introduction*, Third Edition, Springer, 2011.
- [13] B. Chomette, *Contrôles modaux actif, semi-adaptatif et semi-actif de structures intelligentes embarquées, Application aux cartes électroniques*, Thèse, Institut National des Sciences Appliquées de Lyon, 2008.
- [14] S. Hanagud, S. Griffin, *Active Structural Control for a Smart Guitar*, In Proceedings of the 4th European Conference On Smart Structures and Materials, Harrogate, United Kingdom, July 6-8 1998.
- [15] CR. Fuller, SJ. Elliot, PA. Nelson, *Active Control of Vibration*, Academic Press, 1997.
- [16] *Modalys* : Ircam Product, <http://forumnet.ircam.fr/701.html> .
- [17] DB. Sharp, *Acoustic pulse reflectometry for the measurement of musical wind instruments*, PhD Thesis, University of Edinburgh, 1996.
- [18] A. Mamou-Mani, DB. Sharp, T. Meurisse, W. Ring, *Investigating the consistency of woodwind instrument manufacturing by comparing five nominally identical oboes*, J. Acoust. Soc. Amer., Issue 1, pp. 728-736, 2012.